



SEC711-R1 EEV Controller

Installation Instructions

1. Installation and wiring

1.1 Guide rail installation

Installed via the guide rail groove on the back of the controller, suitable for guide rails compliant with DIN 35 standards.

1.2 Overall Dimensions

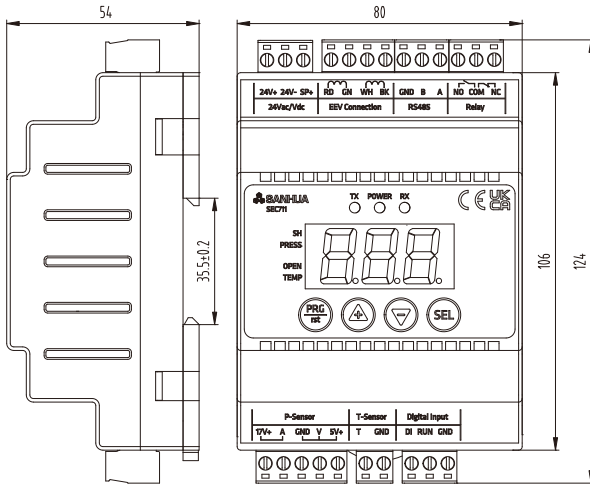

1.3 Wiring

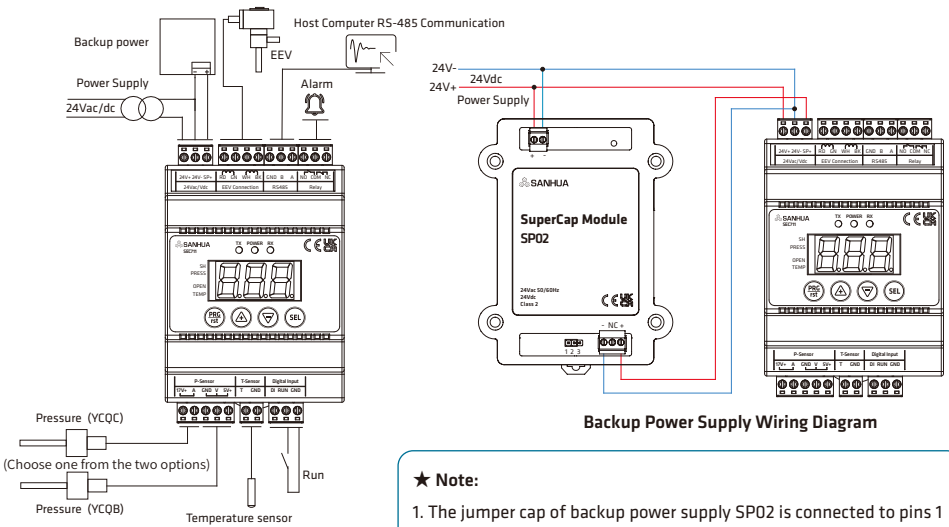

- ★ Note:**
1. The jumper cap of backup power supply SP02 is connected to pins 1 and 2;
 2. When using the backup power supply, both the controller and the backup power supply must be powered by a 24Vdc supply.

Type	Function	Label	Description		
Pluggable terminal	Power Supply/ Backup Power Supply	24Vac/Vdc	24V+	AC24V or DC24V	
			24V-		
			SP+	External Backup Power Supply Positive Terminal	
	Digital Switch Input	Digital Input	DI	Backup Input	
			RUN	Closes during startup and opens during shutdown (except in pressure regulation mode); serves as an evacuation signal under pressure regulation mode.	
			GND	Signal Ground	
	RS485 Communication	RS485	GND	Signal Ground	
			B	485 communication B-	
			A	485 communication A+	
	Pressure Transmitter (Please set its maximum and minimum values when selecting a pressure transmitter)	P-SENSOR	17V+	YCQC Series Current-Type Pressure Transmitter	Power Supply 17Vdc
			A		Input 4-20mA
			GND	YCQB Series Voltage-Type Pressure Transmitter	GND
			V		Signal Input (0.5-3.5)V/ (0.5-4.5)V
			5V+		Power Supply 5Vdc
	Temp. sensor	T-SENSOR	T	NTC5K/ β 3970(NTC3A1、NTC6A1) NTC10K/ β 3977K	
			GND	NTC10K/ β 3435K PT1000	
	Relay Output Port	Relay	NO	Normally Open (NO) Terminal	
			COM	Common Terminal	
			NC	Normally Closed (NC) Terminal	
	EEV Coil	EEV	RD	Connect to a 4-wire bipolar valve	
GN					
WH					
BK					

Note:

- (1) Do not turn on the power before completing the wiring, cut off the power before changing the wiring;
- (2) For the passive connection method of the RUN signal (evacuation signal), please refer to Figure 1; for the active connection method, please refer to Figure 2.



Figure1 Passive Input

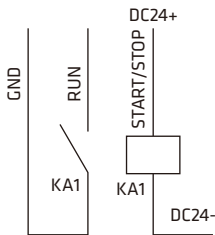

Figure2 Active Input

(3) For the wiring method of the voltage-type pressure transmitter, refer to Figure 3; for the current-type pressure transmitter, refer to Figure 4.

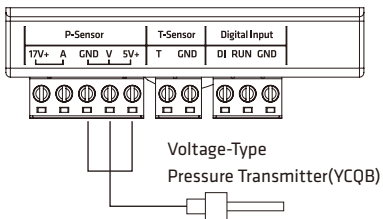

Figure3 Voltage-Type Pressure Transmitter

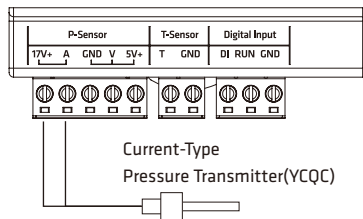
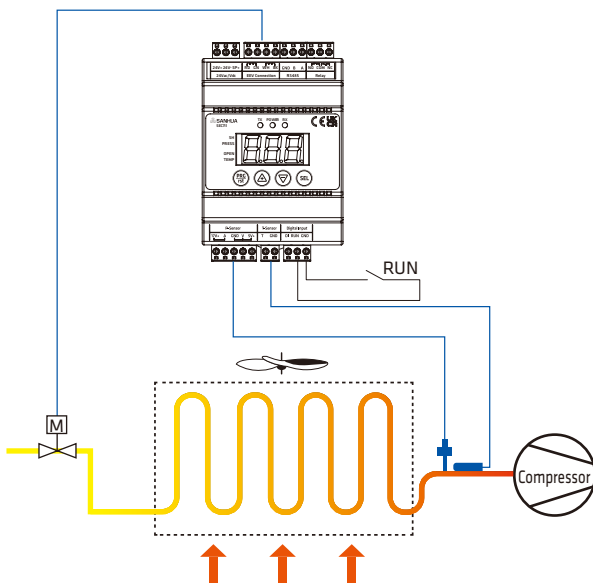

Figure4 Current-Type Pressure Transmitter

(4) We recommend to install the temperature and pressure sensors within 0.5m from the evaporator to prevent ambient temperature and pressure drop interference for the superheat calculation.



2. Buttons and Operation



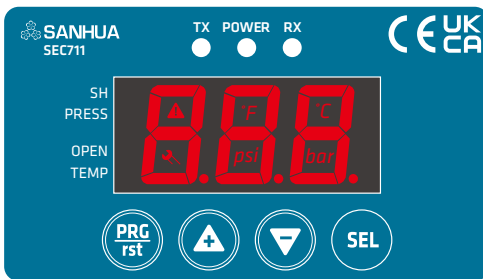





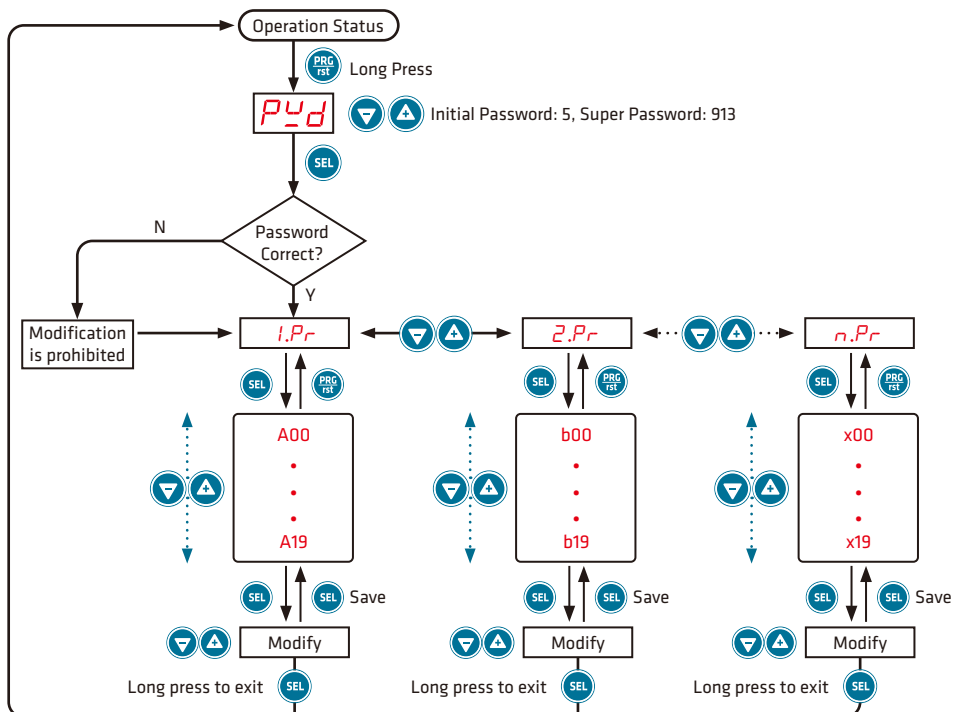



★ By default, it displays the current suction superheat SH; press the ▲ or ▼ key to switch the display content and view other real-time data: PRESS (Pressure), OPEN (Opening), TEMP (Temperature), Saturation Temperature.



Buttons	Description
	Long press to enter parameter setting mode or short press to return to the previous level.
	Increase or scroll up
	Decrease or scroll down
	Select and save

LED	Description	LED	Description
SH	Display current superheat	°C /bar	A metric unit of temperature/pressure
PRESS	Display current pressure	°F /psi	A Imperial unit of temperature/pressure
OPEN	Display current EEV opening (%)		Lighting while alarming
TEMP	Display current temperature		Flickering with forced open valve ratio
	Saturation Temperature	POWER	Lighting at power up
		TX, RX	Flickering at communication





1. During operating status, long press  for more than 3s, enter parameter setting mode;
2. When screen show Pd, press   until screen display "5" (original password), then press  enter parameters table list;
3. *1.Pr*、*2.Pr*、*3.Pr*...represent parameter table 1, 2, 3, etc., represent parameter table 1, 2, 3, etc., respectively. Pressing the button   allows switching between parameter tables.
4. After selecting a parameter table, press  to enter the parameter table. If you want to switch to another parameter table, press  to return to the parameter table selection interface.
5. Press  to confirm the parameter to be modified or viewed, then use the   to change the parameter's value. After completing the modification, press  to save the changes and return to the parameter table.
6. After modifying all parameters, long press  for 3 seconds to exit the settings and return to the initial operation interface.

Note:

- (1) If the password is entered incorrectly or no password is entered, only parameter inquiry is allowed, and parameter modification is not permitted.
- (2) After entering the parameter settings with the correct password, parameter adjustments can be made within 10 minutes. After 10 minutes, re-entering the password is required for further valid operations.
- (3) After entering the parameter settings, if there is no operation within 3 minutes, the interface will automatically exit to the normal operation display screen after exactly 3 minutes.
- (4) If the password is forgotten after modification, you can access the system using the super password, which is 913.

3. Main parameter setting

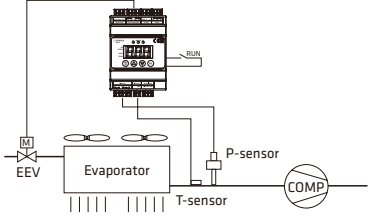
3.1 Controller mode selection

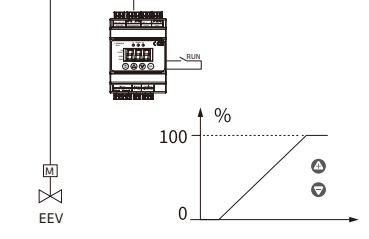
Add.	Set Value	Operating Mode	Description	Wiring
40002	P00	Superheat Control Mode	(Default Mode) Adjust the opening of the electronic expansion valve to control the suction superheat.	
40002	P01	Manual Control Mode	Adjust the opening of the electronic expansion valve directly via the panel buttons   .	

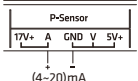
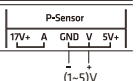
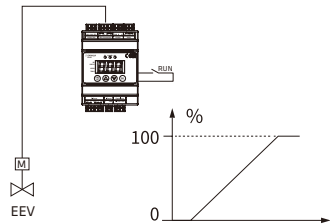
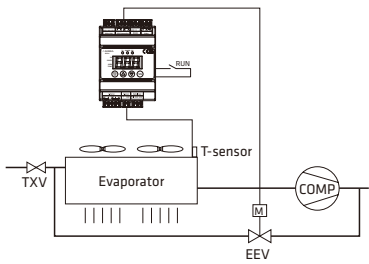
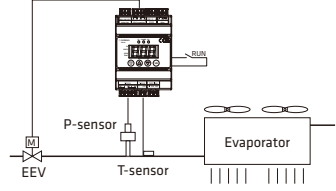
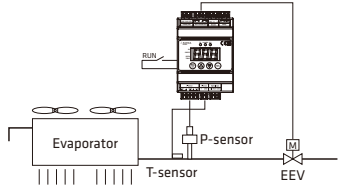
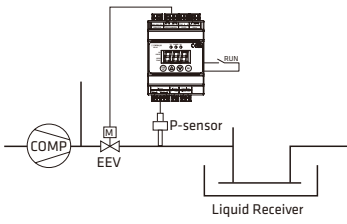
Add.	Set Value	Operating Mode	Description	Wiring
40002	P02	Drive Mode	Drive the valve action by percentage via the external analog signal type (1-5)V or (4-20)mA (determined by [Pressure Transmitter Type] (40032)). <div style="display: flex; justify-content: space-around; margin-top: 10px;"> <div style="text-align: center;">  <p>(4-20)mA</p> </div> <div style="text-align: center;">  <p>(1-5)V</p> </div> </div>	
40002	P03	Temperature Control Mode	Control the opening of the electronic expansion valve via temperature. When parameter [Temperature Control Mode] (40035) is set to 0 (hot gas bypass (default)), the valve closes when the current temperature is higher than the target temperature and opens when it is lower. When set to 1 (liquid injection cooling), the valve opens when the current temperature is higher than the target temperature and closes when it is lower.	
40002	P10	Evaporating Pressure Regulation Mode	P is the actual value, Ps is the set value. Close the valve when $P < P_s$; open the valve when $P > P_s$. Close the valve when the evacuation signal is active.	
40002	P11	Condensing Pressure Regulation Mode	P is the actual value, Ps is the set value. Close the valve when $P < P_s$; open the valve when $P > P_s$. Open the valve when the evacuation signal is active.	
40002	P12	Hot Gas Bypass Pressure Regulation Mode	P is the actual value, Ps is the set value. Open the valve when $P < P_s$; close the valve when $P > P_s$. Close the valve when the evacuation signal is active.	

Add.	Set Value	Operating Mode	Description	Wiring
40002	P13	Liquid Line Pressure Regulation Mode	P is the actual value, Ps is the set value. Open the valve when $P < P_s$; close the valve when $P > P_s$. Open the valve when the evacuation signal is active.	

Note:

- (1) In Manual Control Mode and Drive Mode, the RUN signal must remain continuously connected, and the four indicator lights corresponding to SH, PRESS, OPEN, and TEMP will flash simultaneously.
- (2) Under pressure regulation modes, the device operates by default upon power-up, and the RUN signal serves as the external evacuation signal.
- (3) During normal operation, pressing the once will display the current operating mode code and return after 2 seconds.

Digital tube display	Mode	Digital tube display	Mode
<i>P00</i>	Superheat Mode	<i>P10</i>	Evaporating Pressure Regulation Mode
<i>P01</i>	Manual Mode	<i>P11</i>	Condensing Pressure Regulation Mode
<i>P02</i>	Drive Mode	<i>P12</i>	Hot Gas Bypass Pressure Regulation Mode
<i>P03</i>	Temperature Control Mode	<i>P13</i>	Liquid Line Pressure Regulation Mode

- ★ After selecting a mode, the controller will automatically restart and initialize the relevant parameters (see the table below):
When in operation, press the and the simultaneously; the current operating mode will be displayed, and the device will automatically restart to complete initialization after 5 seconds.

No.	Parameter Address	Parameter Name	Default Initial Value of Superheat Control Mode	Default Initial Value of Manual Control Mode	Default Initial Value of Drive Mode	Default Initial Value of Temperature Control Mode	Default Initial Value of Evaporating Pressure Regulation Mode	Default Initial Value of Condensing Pressure Regulation Mode	Default Initial Value of Hot Gas Bypass Pressure Regulation Mode	Default Initial Value of Liquid Line Pressure Regulation Mode
1	40003	Target Setpoint	M:6.0 US:10.8	M:6.0 US:10.8	M:6.0 US:10.8	M:6.0 US:42.8	M:6.0 US:87	M:6.0 US:87	M:6.0 US:87	M:6.0 US:87
2	40004	Start opening ratio	40				0			
3	40005	Start opening ratio duration time	10				0			
4	40006	P: Proportional gain	5.0				4.0			
5	40007	I: Integral time	30				10			

No.	Parameter Address	Parameter Name	Default Initial Value of Superheat Control Mode	Default Initial Value of Manual Control Mode	Default Initial Value of Drive Mode	Default Initial Value of Temperature Control Mode	Default Initial Value of Evaporating Pressure Regulation Mode	Default Initial Value of Condensing Pressure Regulation Mode	Default Initial Value of Hot Gas Bypass Pressure Regulation Mode	Default Initial Value of Liquid Line Pressure Regulation Mode	
6	40008	D: Derivative time	25				2				
7	40010	Low SH alarm value	M:0.5 US:0.9	M:0.5 US:0.9	M:0.5 US:0.9	M:0.5 US:32.9	M:0.5 US:0.9				
8	40012	Clear low SH alarm value	M:3.0 US:5.4	M:3.0 US:5.4	M:3.0 US:5.4	M:3.0 US:37.4	M:3.0 US:5.4				
9	40013	MOP alarm mode	1								
10	40014	MOP alarm value	M:9.0 US:131	M:9.0 US:131	M:9.0 US:131	M:9.0 US:131	M:19.0 US:276	M:48.0 US:696	M:48.0 US:696	M:19.0 US:276	
11	40016	Clear MOP alarm value	M:8.0 US:116	M:8.0 US:116	M:8.0 US:116	M:8.0 US:116	M:18.0 US:261	M:47.0 US:682	M:47.0 US:682	M:18.0 US:261	
12	40018	High SH alarm value	M:30 US:54	M:30 US:54	M:30 US:54	M:80 US:176	M:30 US:54	M:30 US:54	M:30 US:54	M:30 US:54	
13	40020	Clear high SH alarm	M:27 US:49	M:27 US:49	M:27 US:49	M:70 US:158	M:27 US:49	M:27 US:49	M:27 US:49	M:27 US:49	
14	40028	Low pressure alarm mode	0				1				
15	40029	Low pressure alarm value	M:0 US:0	M:0 US:0	M:0 US:0	M:0 US:0	M:1.0 US:15	M:5.0 US:73	M:5.0 US:73	M:1.0 US:15	
16	40031	Clear low pressure alarm	M:0.3 US:4	M:0.3 US:4	M:0.3 US:4	M:0.3 US:4	M:1.3 US:19	M:5.3 US:77	M:5.3 US:77	M:1.3 US:19	
17	40036	Valve opening management with sensor alarm	50				50	100	0	100	
18	40037	Pressure Regulation Direction	0				0	0	1	1	
19	40038	Evacuation Valve Direction	0				1	0	1	0	
20	40062	Pressure Sensor Maximum Value	20				20	50	50	20	
21	40063	Pressure Sensor Minimum Value	-1				0				
22	40076	Display Mode	1				2				
23	40077	Start/Stop Mode	1				0				

3.2 Refrigerant selection

Refrigerant setting is in **4Pr**.

Add.	Code	Description	Default	Range
40061	R00	Refrigerant	5(R507)	-1~36

Now 37 different refrigerants are available in the controller as below:

NO.	Refrigerant	NO.	Refrigerant	NO.	Refrigerant	NO.	Refrigerant	NO.	Refrigerant
-1(OFF)	Custom	7	R1234yf	15	R744A(N ₂ O)	23	R407H	31	R1270
0	R22	8	R290	16	R32	24	R454C	32	R1233zd(E)
1	R404A	9	R450A	17	R245fa	25	R455A	33	R1234ze(Z)
2	R410A	10	R513A	18	R23	26	R454B	34	R452C
3	R134A	11	R448A	19	R407A	27	R452B	35	R457A
4	R407C	12	R449A	20	R407F	28	R600a	36	R515B
5	R507	13	R452A	21	R124	29	R600		
6	R1234ze(E)	14	R744(CO ₂)	22	R717	30	R454A		

3.3 Target Superheat, Temperature Setting, or Pressure Setting

Add.	Code	Description	Default	Unit	Range
40003	R02	Target Superheat	M:6.0 US:10.8	K	M:0.5~30 US:0.9~54
		Target Temperature	M:6.0 US:42.8	M: °C US: °F	M:-50~150 US:-58~302
		Target Pressure	M:6.0 US:87	M:bar US:psi	M:-1~50 US:-15~725

If the target superheat value is too small, it may lead to incomplete evaporation of the refrigerant; if the target value is too large, the evaporator efficiency will be too low.

3.4 Start opening ratio and duration time

Add.	Code	Description	Default	Unit	Range
40004	R03	Start opening ratio	40	%	0-100
40005	R04	Start opening ratio duration time	10	S	0-999

- 1) After powering on, the electronic expansion valve returns to the fully closed position. Once the compressor start/stop signal (RUN) is connected, the controller will firstly open the electronic expansion valve to the start opening ratio and maintain this opening for start open ratio duration time. After that, the controller will adjust the valve according to the selected control mode.
- 2) Once the controller is set to the forced valve opening ratio for the expansion valve (40073, default -1 for closed state), after the start open ratio duration time is reached, the controller will forcibly open the electronic expansion valve to the set value of 40073 and keep it unchanged. It has higher priority than the set values of 40036 [Valve opening management with sensor alarm], 40070 [Expansion Valve Opening Maximum Value], 40071 [Expansion Valve Opening Minimum Value], and the valve opening control under various alarm modes.
- 3) Start opening ratio and Start opening ratio duration time are not working in manual mode, drive mode and pressure regulation mode.

3.5 Auxiliary Relay Output (AUX-RLY, selectable between normally open or normally closed contacts)

(1) Alarm Output (default state is off, with parameter 40026 set to -1).

(2) Evacuation Function (used for low-pressure shutdown): When parameter 40026 is set to a value other than -1, the evacuation function is activated.

Add.	Code	Description	Default	Unit	Range
40026	b05	Select Evacuation Function and Delay Time	-1(OFF)	Sec	-1-180
40027	b06	Pressure Setpoint for Stopping Evacuation	M: 0.5 US: 7	M:bar US:psi	M: -0.5-18 US: -7-261

Once the compressor start/stop signal (RUN) is disconnected, the controller will firstly close the electronic expansion valve completely. When the system suction pressure is lower than **[Pressure Setpoint for Stopping Evacuation]** (address 40027) or exceeds the set value for **[Select Evacuation Function and Delay Time]** (address 40026), the auxiliary relay output signal switches to stop the compressor.

3.6 Reset to factory settings

Add.	Code	Description	Default	Range
40080	d19	Reset	0	0-999

Reset is in **4Pr**, press **SEL** to find the parameter **d19**, input the password or alternate password 913 and long press **SEL**, all parameters are reset to the default from factory and restart operation.

4. Parameters table

4.1 Parameter table **IPr**

Add.	Description	Code	Unit	Step	Min.	Max.	Default
40001	Controller mode selection	AD0	0=Metric (M) bar/°C; 1=Imperial (US) psi/°F				0
40002	Controller mode selection	AD1	P00(0): Superheat Control Mode P01(1): Manual Control Mode P02(2): Drive Mode P03(3): Temperature Control Mode P10(10): Evaporating Pressure Regulation Mode P11(11): Condensing Pressure Regulation Mode P12(12): Hot Gas Bypass Pressure Regulation Mode P13(13): Liquid Line Pressure Regulation Mode				P00(0)
40003	Superheat setpoint	AD2	K	0.1	M:0.5 US:0.9	M:30 US:54	M:6.0 US:10.8
	Temperature Setpoint		M: °C US: °F	0.1	M:-50 US:-58	M:150 US:302	M:6.0 US:42.8
	Target Pressure		M:bar US:psi	M:0.1 US:1	M:-1 US:-15	M:50 US:725	M:6.0 US:87
40004	Start opening ratio	AD3	%	1	0	100	40
40005	Start opening ratio duration time	AD4	Sec	1	0	600	10
40006	P: Proportional gain	AD5	%	0.1	0.1	99.9	5.0
40007	I: Integral time	AD6	Sec	1	0	999	30
40008	D: Derivative time	AD7	Sec	1	0	999	25
40009	Low SH alarm mode	AD8	0=Off; 1=Auto Reset; 2=Manual Reset				0

Add.	Description	Code	Unit	Step	Min.	Max.	Default
40010	Low SH alarm value	A09	K	0.1	M:0.5 US:0.9	M:30 US:54	M:0.5 US:0.9
40011	Low SH alarm delay time	A10	Sec	1	1	300	15
40012	Low SH alarm delay time	A11	K	0.1	M:1 US:1.8	M:30.5 US:54.9	M:3 US:5.4
40013	MOP alarm mode	A12	0=Off; 1=Auto Reset				1
40014	MOP alarm value	A13	M:bar US:psi	M:0.1 US:1	M:-1 US:-15	M:50 US:725	M:9 US:130
40015	MOP alarm delay time	A14	Sec	1	0	999	60
40016	Clear MOP alarm	A15	M:bar US:psi	M:0.1 US:1	M:1 US:1.8	M:30.5 US:54.9	M:8 US:116
40017	High SH alarm mode	A16	0=Off; 1=Auto Reset; 2=Manual Reset				0
40018	High SH alarm value	A17	K	1	M:10 US:18	M:40 US:72	M:30 US:54
40019	High SH alarm delay time	A18	Min	1	1	600	3
40020	Clear high SH alarm	A19	K	1	M:7 US:13	M:37 US:67	M:27 US:49

4.2 Parameter table **2Pr**

Add.	Description	Code	Unit	Step	Min.	Max.	Default
40021	MOP Integral Valve Closing Coefficient	b00	/	1	0	800	200
40022	Freeze Protection alarm mode	b01	0=Off; 1=Auto Reset; 2=Manual Reset				0
40023	Freeze Protection alarm value	b02	M: °C US: °F	1	M:-40 US:-40	M:40 US:104	M:0 US:32
40024	Freeze Protection alarm delay time	b03	Sec	1	5	200	30
40025	Clear Freeze Protection alarm	b04	M: °C US: °F	1	M:-37 US:-34	M:43 US:109	M:3 US:37
40026	Select Evacuation Function and Delay Time	b05	Sec	1	-1	180	-1(OFF)
40027	Pressure Setpoint for Stopping Evacuation	b06	M:bar US:psi	M:0.1 US:1	M:-0.5 US:-7	M:18 US:261	M:0.5 US:7
40028	Low Pressure Alarm Mode	b07	0=Off; 1=Auto Reset; 2=Manual Reset				0
40029	Low Pressure Alarm Setpoint	b08	M:bar US:psi	M:0.1 US:1	M:-0.8 US:-12	M:177 US:256	M:0 US:0
40030	Low Pressure Alarm Delay Time	b09	Sec	1	5	200	5
40031	Clear Low Pressure Alarm	b10	M:bar US:psi	M:0.1 US:1	M:-0.5 US:-7	M:18 US:261	M:0.3 US:4
40032	Pressure transmitter type	b11	0=(0.5~3.5)V; 1=(0.5~4.5)V; 2=(4~20)mA				1
40033	Pressure Transmitter Short Circuit Alarm	b12	0=close 1=open				0
40034	Shutdown Delay	b13	0~999s After the compressor start/stop signal (RUN) is disconnected, the valve action will be executed after a certain delay time.				0
40035	Temperature control mode	b14	0 Hot Gas Bypass: When the current temperature is higher than the target temperature, the valve closes (reduces opening); conversely, it opens (increases opening). 1 Liquid Injection Cooling: When the current temperature is greater than the target temperature, the valve opens wider; conversely, it closes.				0

Add.	Description	Code	Unit	Step	Min.	Max.	Default
40036	Valve opening management with sensor failure	b 15					50
							This parameter is valid under the following alarms: Pressure Transmitter Open Circuit (P_{OP}), Pressure Transmitter Short Circuit (P_{ST}), Temperature Sensor Open Circuit (T_{OP}), and Temperature Sensor Short Circuit Alarm (T_{ST}). -1 = Maintain current valve opening unchanged 0 = Valve closed 1-100 = Valve maintains at this opening
40037	Pressure Regulation Direction	b 16					Evaporating Pressure Regulation: 0 Condensing Pressure Regulation: 0 Hot Gas Bypass Pressure Regulation: 1 Liquid Line Pressure Regulation: 1
							0: Forward When $P < P_s$, close the valve; when $P > P_s$, open the valve. 1: Reverse When $P < P_s$, open the valve; when $P > P_s$, close the valve. (This parameter is invalid under non-pressure regulation modes)
40038	Pressure Regulation Evacuation Shutdown Direction	b 17					Evaporating Pressure Regulation:1 Condensing Pressure Regulation:0 Hot Gas Bypass Pressure Regulation:1 Liquid Line Pressure Regulation:0
							0: Forward When the evacuation signal is active, close the valve. 1: Reverse When the evacuation signal is active, open the valve. (This parameter is invalid under non-pressure regulation modes)

1、Alarm setting:

Valve opening management with sensor failure: When the pressure transmitter is open or short-circuited, or when the temperature sensor is open or short-circuited, the controller will generate the corresponding alarm. The controller will then take action based on the pre-defined value of [Valve opening management with sensor failure] (40036). When the corresponding alarm settings for LoP (Low Pressure), LSh (Low Superheat), HSh (High Superheat), and FrE (Anti-freeze) are activated, and once the respective thresholds are exceeded and maintained for the corresponding duration, the controller will generate the corresponding alarm, the valve will be fully closed when triggered by LoP , LSh , HSh , and the valve will be alarmed only when triggered by FrE .

2、MOP Integral Valve Closing Function:

When the [MOP Alarm Mode] (40013) is set to 0, there is no MOP alarm or MOP integral valve closing function;

When the [MOP Alarm Mode] (40013) is set to 1 and the [MOP Integral Valve Closing Coefficient] (40021) is set to 0, there is an MOP alarm function, but the valve does not close after the alarm;

[MOP Alarm Mode] (40013) is set to 1, and [MOP Integral Valve Closing Coefficient] (40021) is not 0: When the actual pressure exceeds the [MOP Alarm Setpoint] (40014), the MOP protection function is activated, interrupting the superheat control. The

valve then closes at a specific rate to regulate pressure. Since the valve-closing action follows an integral mechanism, the closing rate directly depends on the difference between the actual pressure and the **[MOP Alarm Setpoint]** (40014), as well as the set value of the **[MOP Integral Valve Closing Coefficient]** (40021). The greater the pressure exceeds the **[MOP Alarm Setpoint]** (40014), the smaller the set value of the **[MOP Integral Valve Closing Coefficient]** (40021), resulting in faster valve closure. Conversely, a larger **[MOP Integral Valve Closing Coefficient]** (40021) set value leads to slower valve closure when the actual pressure deviates only slightly above the **[MOP Alarm Setpoint]** (40014).

If the actual pressure drops below the **[MOP Alarm Setpoint]** (40014) during the valve-closing process, the MOP integral valve closing function is canceled, and automatic superheat regulation resumes.

Examples:

- 1.If the **[MOP Alarm Setpoint]** (40014) is set to 90, and the **[MOP Integral Valve Closing Coefficient]** (40021) is set to 800, with the current pressure maintained at 91, the valve closing rate is: 10% closure within 60 seconds.
- 2.If the **[MOP Alarm Setpoint]** (40014) is set to 90, and the **[MOP Integral Valve Closing Coefficient]** (40021) is set to 1, with the current pressure maintained at 91, the valve will immediately close fully at maximum speed to 0%.

4.3 Parameter table *3Pr*

Add.	Description	Code	Unit	Step	Min.	Max.	Default
40041	Valve Type Selection	C00	0 = Custom Mode 1 = VPF150、VPF250、VPF400 2 = VPF100 3 = VPF50 4 = VPF12.5、VPF25 5 = VPF250H22/23、VPF400L03/83、VPF400H10/90				1
40042	Drive Current	C01	mA	1	0	533	90
40043	Standby Current	C02	mA	1	0	40	20
40044	Expansion valve total pulse	C03	×10pulse	1	0	999	380
40045	Expansion Valve Opening Pulse	C04	pulse	1	0	999	165
40046	EEV drive speed	C05	pps	1	10	500	200
40047	Over-driver steps to close the EEV	C06	pulse	1	0	999	100
40048	Over-drive steps to reset the EEV	C07	%	1	0	100	10
40049	EEV closing speed when power off	C08	pps	1	10	500	200
40050	Expansion Valve Direction	C09	0=Forward; 1=Reverse				0
40055	Drive mode zero point	C14	%	0.1	0	5	1.0
40056	Drive mode full scale point	C15	%	0.1	95	100	99.0
40057	485 Communication control opening	/	In superheat control mode or drive mode: -1(OFF): External analog control mode. 1V~5V or 4~20mA corresponds to a valve opening of 0~100% 0 to maximum pulses: Communication-controlled opening, corresponding to 0~100% opening. Only supported via 485 communication settings.				-1(OFF)

Add.	Description	Code	Unit	Step	Min.	Max.	Default
40058	Refrigerant User-defined parameter A1	/	A1: Min -20000 Max 20000 A2: Min -20000 Max 20000 A3: Min -20000 Max 20000				(R507) A1:9770 A2:-1975 A3:2488
40059	Refrigerant User-defined parameter A2	/	When the refrigerant type parameter 40061 is set to -1, the custom mode is enabled.				
40060	Refrigerant User-defined parameter A3	/	A1, A2, and A3 are custom parameters, only configurable via 485 communication.				

- (1) Parameter Table 3 (40042~40050) is usually not used, SANHUA standard EEV can directly set by the DIP SW. If you want modify parameters table 3 (40042~40050), please change DIP SW firstly , after setting this table, the controller need to cut off power and restart again.
- (2) Since the maximum display value of the controller is 999, a value of 380 for [Expansion valve total pulse] (40044) represents 3800 steps.
- (3) When the customized parameters(40042~40050)are set according to the specification of the selected electronic expansion valve and please follow them strictly
- (4) Valve opening control in drive mode has nothing to do with the setting values of [Maximum Expansion Valve Opening] (40070)、 [Minimum Expansion Valve Opening] (40071) and [EEV compulsory opening ratio] (40073).
- (5) In the scenario of 485 communication control valve opening, it must be controlled by writing the parameter [485 communication control opening] (40057), and it cannot be controlled by writing the parameter [EEV compulsory opening ratio] (40073), and the parameter [EEV compulsory opening ratio] (40073) needs to be set to -1 (OFF).
- (6) Parameter [485 communication control opening] (40057) is valid in both superheat control mode and drive mode.
- (7)Parameter [EEV compulsory opening ratio] (40073) is used when it is necessary to set the valve to keep a fixed opening, and this parameter will be saved after power off.

4.4 Parameter table *4Pr*

Add.	Description	Code	Unit	Step	Min.	Max.	Default
40061	Refrigerant	<i>d00</i>	-1=Customized 3=R134a 7=R1234yf 11=R448A 15=R744A(N ₂ O) 19=R407A 23=R407H 27=R452B 31=R1270 35=R457A	0=R22 4=R407C 8=R290 12=R449A 16=R32 20=R407F 24=R454C 28=R600A 32=R1233zdE 36=R515B	1=R404A 5=R507 9=R450A 13=R452A 17=R245fa 21=R124 25=R455A 29=R600 33=R1233zeZ	2=R410A 6=R1234ze 10=R513A 14=R744(CO ₂) 18=R23 22=R717 26=R454B 30=R454A 34=R452C	5
40062	Pressure sensor MAX. value	<i>d01</i>	M:bar US:psi	M:0.1 US:1	M:-1 US:-19	M:99 US:999	M:20 US:290
40063	Pressure sensor MIN. value	<i>d02</i>	M:bar US:psi	M:0.1 US:1	M:-1 US:-19	M:99 US:999	M:-1 US:-15
40064	Pressure sensor offset correction	<i>d03</i>	M:bar US:psi	M:0.1 US:1	M:-9.9 US:-144	M:9.9 US:144	0
40065	Temp. sensor offset correction	<i>d04</i>	M:K US:°F	0.1	M:-19.9 US:-36.0	M:19.9 US:36.0	0
40066	Password	<i>d05</i>	/	1	0	999	5
40069	Coil excitation speed upper limit	<i>d08</i>	/	0.1	0.1	100	100
40070	Maximum Expansion Valve Opening	<i>d09</i>	%	1	0	100	100

Add.	Description	Code	Unit	Step	Min.	Max.	Default
40071	Minimum Expansion Valve Opening	d 10	%	1	0	100	0
40072	Sensor input filter time	d 11	/	0.1	0.1	10	1
40073	EEV compulsory opening ratio	d 12	%	0.1	0	100	-1(OFF)
40074	Temperature sensor type	d 13	0=5K(-55~105)° C β:3970K 1=10K(-40~150)° C β:3977K 2=10K(-50~110)° C β:3435K 3=PT1000(-100~105)° C				0
40075	EEV reset mode	d 14	0 = Fully close; 1 = Fully open to fully close				0
40076	Display mode	d 15	0=1~4 rotation 1= Superheat 2=Evaporator outlet pressure 3= Expansion valve open ratio 4= Evaporator outlet temperature 5= Saturation temperature				1
40077	Run/stop method	d 16	0= Always run 1= Digital input 2= Communication Run				1
40078	Communication ID setup	d 17	/	1	1	254	1
40079	Communication Speed Setting	d 18	0 (2400 8 data bits, no parity, 1 stop bit) 1 (4800 8 data bits, no parity, 1 stop bit) 2 (9600 8 data bits, no parity, 1 stop bit) 3 (19200 8 data bits, no parity, 1 stop bit) 4 (38400 8 data bits, no parity, 1 stop bit) 5 (2400 8 data bits, even parity, 1 stop bit) 6 (4800 8 data bits, even parity, 1 stop bit) 7 (9600 8 data bits, even parity, 1 stop bit) 8 (19200 8 data bits, even parity, 1 stop bit) 9 (38400 8 data bits, even parity, 1 stop bit) 10 (2400 8 data bits, odd parity, 1 stop bit) 11 (4800 8 data bits, odd parity, 1 stop bit) 12 (9600 8 data bits, odd parity, 1 stop bit) 13 (19200 8 data bits, odd parity, 1 stop bit) 14 (38400 8 data bits, odd parity, 1 stop bit) 15 (2400 8 data bits, no parity, 2 stop bits) 16 (4800 8 data bits, no parity, 2 stop bits) 17 (9600 8 data bits, no parity, 2 stop bits) 18 (19200 8 data bits, no parity, 2 stop bits) 19 (38400 8 data bits, no parity, 2 stop bits) 20 (2400 8 data bits, even parity, 2 stop bits) 21 (4800 8 data bits, even parity, 2 stop bits) 22 (9600 8 data bits, even parity, 2 stop bits) 23 (19200 8 data bits, even parity, 2 stop bits) 24 (38400 8 data bits, even parity, 2 stop bits) 25 (2400 8 data bits, odd parity, 2 stop bits) 26 (4800 8 data bits, odd parity, 2 stop bits) 27 (9600 8 data bits, odd parity, 2 stop bits) 28 (19200 8 data bits, odd parity, 2 stop bits) 29 (38400 8 data bits, odd parity, 2 stop bits)				2
40080	Reset	d 19	/	1	0	999	0

- (1) Setting the [EEV compulsory opening ratio] (40073) of the Electronic Expansion Valve (EEV) to -1 indicates disabling forced control of the EEV and resuming automatic control.
- (2) While restoring to the factory settings, change the corresponding parameter to the password value (the default value is 5 or the standby password is 913), long press the key  and then the controller will restart and restore successfully.
- (3) By modifying the communication settings through RS485, the changes will only take effect after power off and restart. While modifying the communication settings using buttons, the changes take effect immediately.
- (4) [EEV compulsory opening ratio] (40073) is valid in the automatic superheat control mode and temperature control mode.

5. Alarm information

1. When the controller triggers an alarm, the 7-segment display alarm indicator light  turns on, and alternates between displaying the normal operation interface and the fault codes.

Alarm codes are listed in the table below:

Code	Alarm information	Mode							
		Super-heat	Manual	Drive	Temperature	Evaporating Pressure	Condensing Pressure	Heat Gas Bypass Pressure	Liquid Pipe Pressure
<i>S_tP⁽¹⁾</i>	Start/Stop Signal (RUN) Disconnected	√	√	√	√	×	×	×	×
<i>P_oP</i>	Pressure Transmitter Not Connected	√	×	×	×	√	√	√	√
<i>P_St</i>	Pressure Transmitter Short Circuit	√	×	×	×	√	√	√	√
<i>t_oP</i>	Temperature Sensor Not Connected	√	×	×	√	×	×	×	×
<i>t_St</i>	Temperature Sensor Short Circuit	√	×	×	√	×	×	×	×
<i>n_oP</i>	MOP High Pressure Alarm	√	×	×	×	√	√	√	√
<i>L_oP</i>	LOP Low Pressure Alarm	√	×	×	×	√	√	√	√
<i>H_SH</i>	High Temperature/High Superheat Alarm	√	×	×	√	×	×	×	×
<i>L_SH</i>	Low Temperature/Low Superheat Alarm	√	×	×	√	×	×	×	×
<i>F_rE</i>	Freeze Protection Alarm	√	×	×	×	×	×	×	×

Note:

- (1) When the Start/Stop Signal (RUN) is disconnected, "*S_tP*" is displayed and does not indicate an alarm, which only serves as a operating status reminder. This code will disappear after the RUN start/stop signal line is closed during system operation.
- (2) For MOP Alarm: After the system suction pressure exceeds the set value and surpasses the delay time, an alarm is triggered, and the electronic expansion valve is forced to close.
- (3) √ indicates detection; × indicates no detection.

2. Address 40310 Alarm Flag Bit

bit	15	14	13	12	11	10	9	8	7	6	5	4	3	2	1	0
alarm						<i>F_rE</i>	<i>L_SH</i>	<i>H_SH</i>	<i>L_oP</i>	<i>n_oP</i>			<i>t_St</i>	<i>t_oP</i>	<i>P_St</i>	<i>P_oP</i>

A flag bit value of 0 indicates no fault/protection; a flag bit value of 1 indicates a fault/protection.

6. Status of Communication table

Add.	Function	Unit	Type	Byte	SEC711	MMI
40073	EEV compulsory open ratio	-	Analog	INT16	0.0~100.0	×10
40099	Analog	-	Analog	INT16	0:OFF	1:ON
40301	Run/Stop input	-	Analog	INT16	0:Stop	1:Run
40302	Switch signal enable	-	Digital	INT16	When the start/stop method (40077) is set to 2 communication run 40302: 1 40303: 0 Power on 40302: 0 40303: 1 Power off	
40303	Switch signal closed	-	Digital	INT16		
40308	Operation status	-	Analog	INT16	Determined by the subsequent digital signal.	
Bit0	Relay Output	-	Digital	bit	0:OFF	1:ON
Bit2	Operation status of EEV	-	Digital	bit	0:OFF	1:ON
Bit15	Total Alarm	-	Digital	bit	0:OFF	1:ON
40310	Temp. sensor short circuit	-	Analog	INT16	Determined by the subsequent digital signal.	
Bit0	Pressure sensor disconnection	-	Digital	bit	0:OFF	1:ON
Bit1	Press. sensor short circuit	-	Digital	bit	0:OFF	1:ON
Bit2	Temp. sensor disconnection	-	Digital	bit	0:OFF	1:ON
Bit3	Temp. sensor short circuit	-	Digital	bit	0:OFF	1:ON
Bit6	HP Pressure Alarm	-	Digital	bit	0:OFF	1:ON
Bit7	LOP Low Pressure Alarm	-	Digital	bit	0:OFF	1:ON
Bit8	HSH High superheat alarm	-	Digital	bit	0:OFF	1:ON
Bit9	LSH Low superheat alarm	-	Digital	bit	0:OFF	1:ON
Bit10	FRE Freezing Protection alarm	-	Digital	bit	0:OFF	1:ON
40312	Present Superheat	K	Analog	INT16	-55.0~200.0	×10
40313	Present saturation temperature	M: °C US: °F	Analog	INT16	M:-55.0~200.0 US:-67.0~392.0	×10
40314	Present pressure	M:bar US:psi	Analog	INT16	M:-1.0~99.0 US:-15~1436	M: ×10 US: ×1
40317	Present temperature	M: °C US: °F	Analog	INT16	M:-100.0~200.0 US:-148.0~392.0	×10
40319	EEV opening ratio	%	Analog	INT16	0.0~100.0	×10

7. Communication

1. Supports the standard RS485 Modbus RTU protocol (2-wire, half-duplex), with a maximum of 31 units cascaded. It is recommended to connect a 120Ω terminating resistor in parallel on the last unit.
2. Communication cables must use twisted shielded wires, preferably $2 \times (0.2 \sim 0.5)\text{mm}^2$. The shield of the wiring terminal should be grounded at one end only.
3. Normal communication with this controller can be achieved when the host computer ID is 255 or the ID matches **[Communication ID Setting]** (40078).
4. Regarding communication baud rate: Within 4 seconds after power-on, the controller communicates at 9600bps, 8 data bits, no parity, 1 stop bit. If normal communication is established, the controller will continue operating at 9600bps, 8 data bits, no parity, 1 stop bit after 4 seconds. If normal communication at 9600bps, 8 data bits, no parity, 1 stop bit fails within 4 seconds, the controller will instead operate at the baud rate specified in **[Communication Speed Setting]** (40079) after 4 seconds.
5. Transmission line connection

Item	Description
Transmission line connection	Multi-line Transmission
Multi-line Transmission	RS485 (2-wire, half-duplex)
Communication Address	Default: 1, Range: (1~254)
Baud-rate	Default 9600bps, Range(2400~38400)bps
Parity, Data, Stop bit	No parity/even parity /odd parity, 8 data, 1 stop bit/2 stop bits Default: no parity, 8 data, 1 stop bit
Protocol Type	Modbus RTU
Function Code	0x03、0x06、0x10
Max. Read Word	32
Cable Type	Belden 9841/9842, LG LIREV-AMESB
Poll interval	≥100ms

Function Code description:

0x03 is used for reading data, 0x06 is used for writing a single parameter and 0x10 is used for writing multiple consecutive parameters at a time (up to 100 parameters).

8. Technical Parameters

Item	Parameter	Item	Parameter
Operating Voltage	24Vac (20~28) Vac, 50/60Hz or 24Vdc (20~28) Vdc	Communication Method	RS485, (default)9600, 8, N, 1
Maximum Power	20VA (24Vac) or 10W (24Vdc) with VPF valve; 30VA (24Vac) or 15W (24Vdc) with 1-5/8 inch electric ball valve	Protection Grade	IP20
Switch Signal	One start/stop signal channel with passive input, and the other channel is used as a backup.	Installation Method	Guide Rail Din 35mm (EN 60715)
Pressure Transmitter	(0.5~3.5)Vdc or (0.5~4.5)Vdc or (4~20) mA	Work Temperature	-30°C~60°C, Humidity≤95%RH(no condensation)
Temperature Sensor	5K(-55°C~105°C) β:3970K 10K(-40°C~150°C) β:3977K 10K(-50°C~110°C) β:3435K PT1000(-100°C~105°C)	Storage Temperature	-40°C~70°C, Humidity≤95%RH(no condensation)
Drive Load	Bipolar 4-wire Valve	Environmental Pollution Grade	2
Backup Power Supply	Externally optional SP02 (please contact Sanhua staff)	Insulation Grade	II
Surge Voltage Resistance	Class II	Certification	CE、UKCA
EMC Compliance	IEC61000-4-2, IEC61000-4-3, IEC61000-4-4, IEC 61000-4-5, IEC61000-4-6, IEC61000-4-11		